



EUROGRAPHICS2017

The 38th annual conference of the
EUROPEAN ASSOCIATION FOR COMPUTER GRAPHICS

Topology Optimization for Computational Fabrication

Jun Wu, Niels Aage, Sylvain Lefebvre, Charlie Wang



Part One: Advanced Manufacturing

Charlie C. L. Wang

Delft University of Technology

April 24, 2017

Conventional Manufacturing Processes

- ▶ **Net Shape Processes**
 - ▶ Forging, drawing, extrusion, rolling
 - ▶ Sheet metal forming, bending
 - ▶ Die casting, investment casting
 - ▶ Injection modeling
- ▶ **Subtractive Processes**
 - ▶ Lathing, milling, grinding, drilling,
 - ▶ Water jetting, laser cutting, etc.

Challenges for Designers (An Example)

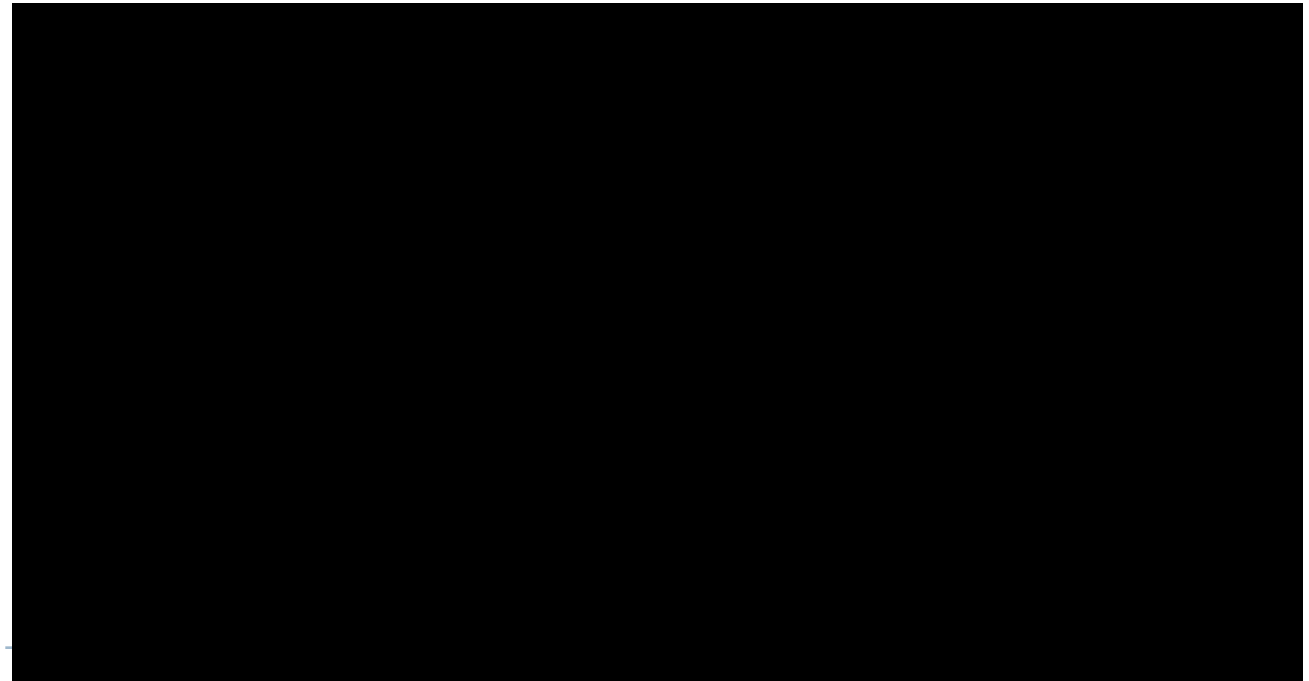

Challenges for Designers (Cont.)

▶ Conventional Mouse – produced by Injection Molding

▶ Problems:

- ▶ Complex shape? **No**
- ▶ Moldability? **Important**
- ▶ Flexibility? **No**
- ▶ Customization? **No**



<http://www.imould.com>

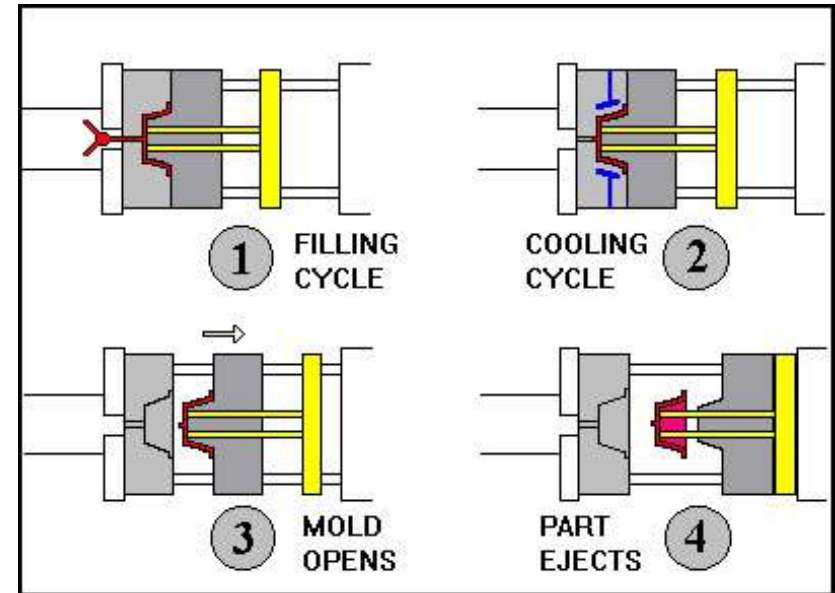

<http://mold-technology4all.blogspot.nl/>

▶ Process to make a mold

- ▶ Mold design (**professional**)
- ▶ CNC machining (**expensive**)

Challenges for Designers

- ▶ **Design a product**
 - ▶ Cannot be fabricated
 - ▶ Shape limitation
 - ▶ Cannot have too many parts
 - ▶ Otherwise, having a high cost
- ▶ **Design for manufacturing** ^[1]
 - ▶ Rule 1: Reduce the total number of parts
 - ▶ Rule 2: Design for easy-to-fabrication
 - ▶ Rule 3: Use of standard components
- ▶ **Main Problem:**
 - ▶ Conventional manufacturing lacks of flexibility

[1] *Computer-Aided Manufacturing*, 2nd Ed., T.-C. Chang, R.A. Wysk, and H.-P. Wang, Prentice Hall, 1998.

Additive Manufacturing

- ▶ Defined by ASTM as:
 - ▶ Process of joining materials to make objects from 3D model data, usually layer upon layer
- ▶ Six Different Types of AM:
 - ▶ Lasers: Stereolithography Apparatus (SLA), Selective Laser Sintering (SLS)
 - ▶ Nozzles: Fused Deposition Modeling (FDM)
 - ▶ Print-heads: Multi-jet Modeling (MJM), Binder-jet Printing (3DP)
 - ▶ Cutters: Laminated Object Modeling (LOM)
- ▶ Mainly used for Rapid Prototyping (Past)
- ▶ More and More used for 'Mass'-Production (Present)

Benefit of Additive Manufacturing

- ▶ Very flexible: **direct digital fabrication** from CAD models
- ▶ Rapid fabrication
- ▶ **Excellent for customization**
- ▶ Manufacturing is responsible for 33% of the world's carbon footprint – AM has minimal material waste

Subtractive Machining:



5000 lb.
forged billet

—

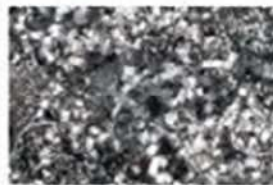

4750 lb.
chips

=

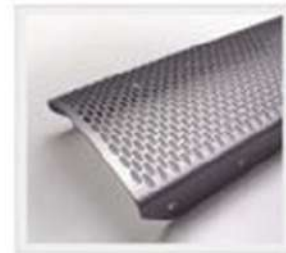

250 lb. finish
machined part

20 : 1
Buy to fly

Limitations / Challenges

- ▶ Limited part sizes
- ▶ Limited fabrication speed
- ▶ Limited materials (20k vs. 200 materials)
- ▶ Poor surface finish / low accuracy
- ▶ Inconsistent part quality
- ▶ High cost (machine, material, pre- and post-processing)

General functional principle of laser-sintering

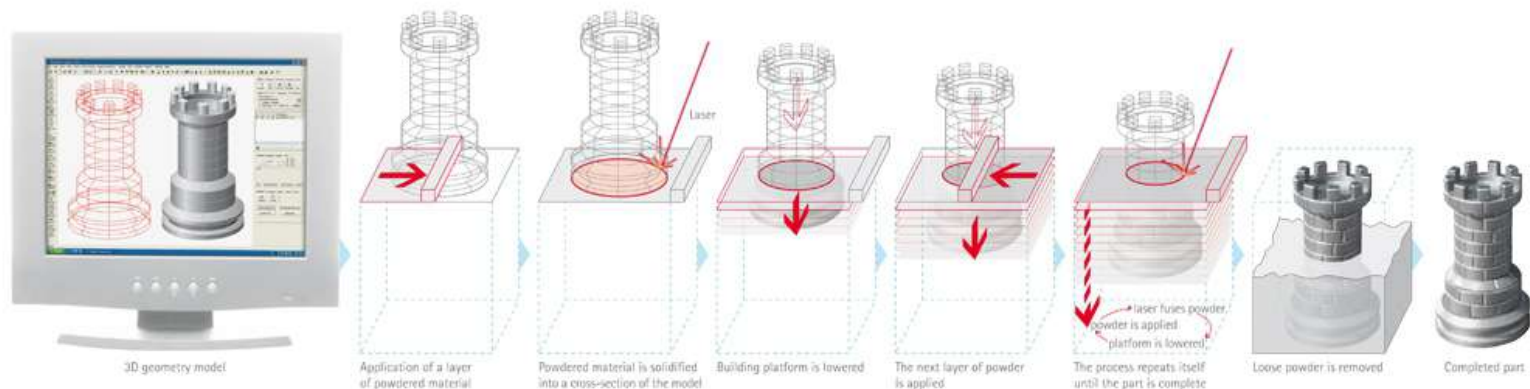

Break-even Analysis of Conventional Manufacturing and 3D Printing

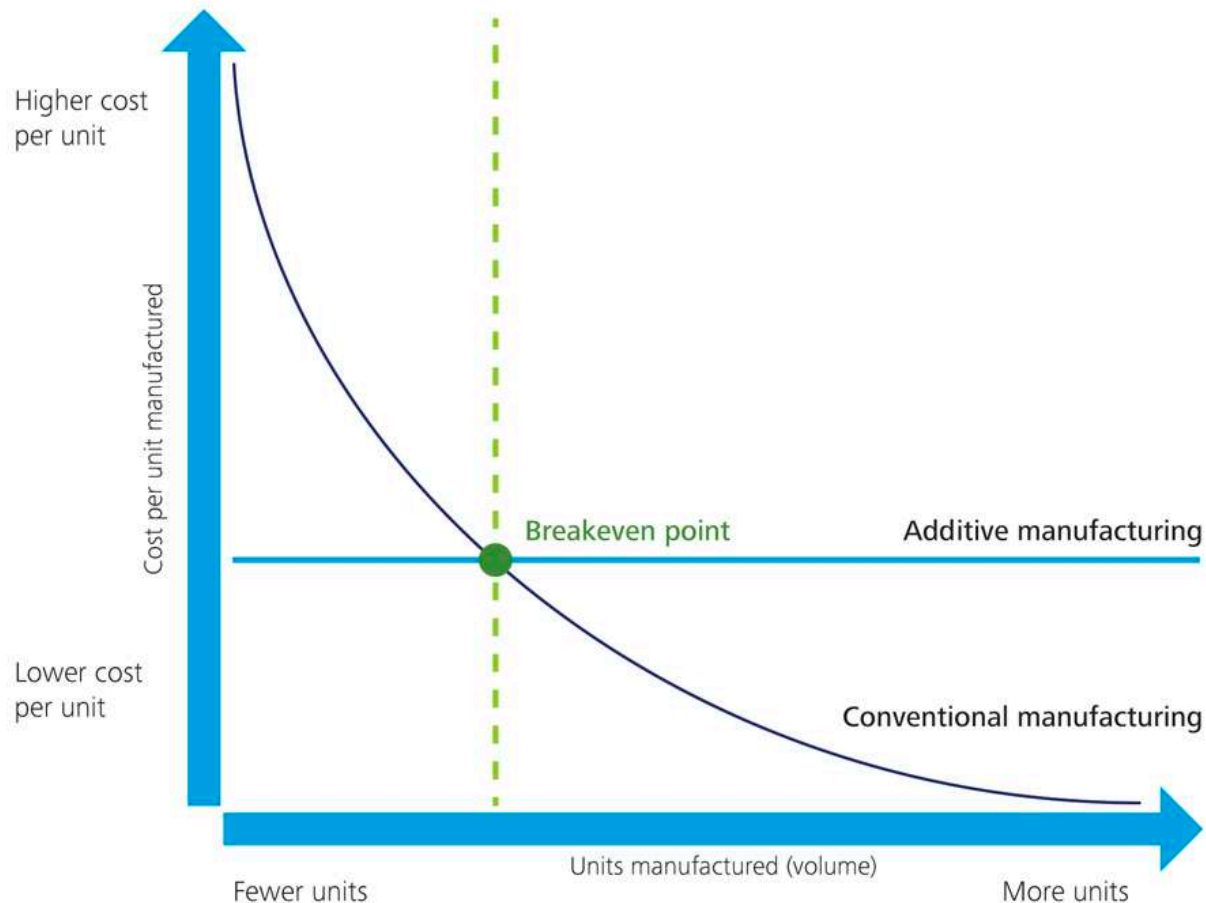

Source: Mark Cotteleer and Jim Joyce, *3D opportunity: Additive manufacturing paths to performance, innovation, and growth*, Deloitte University Press, <http://dupress.com/articles/dr14-3d-opportunity/>, accessed March 17, 2015.

Graphic: Deloitte University Press | DUPress.com

Main Computation Steps in AM

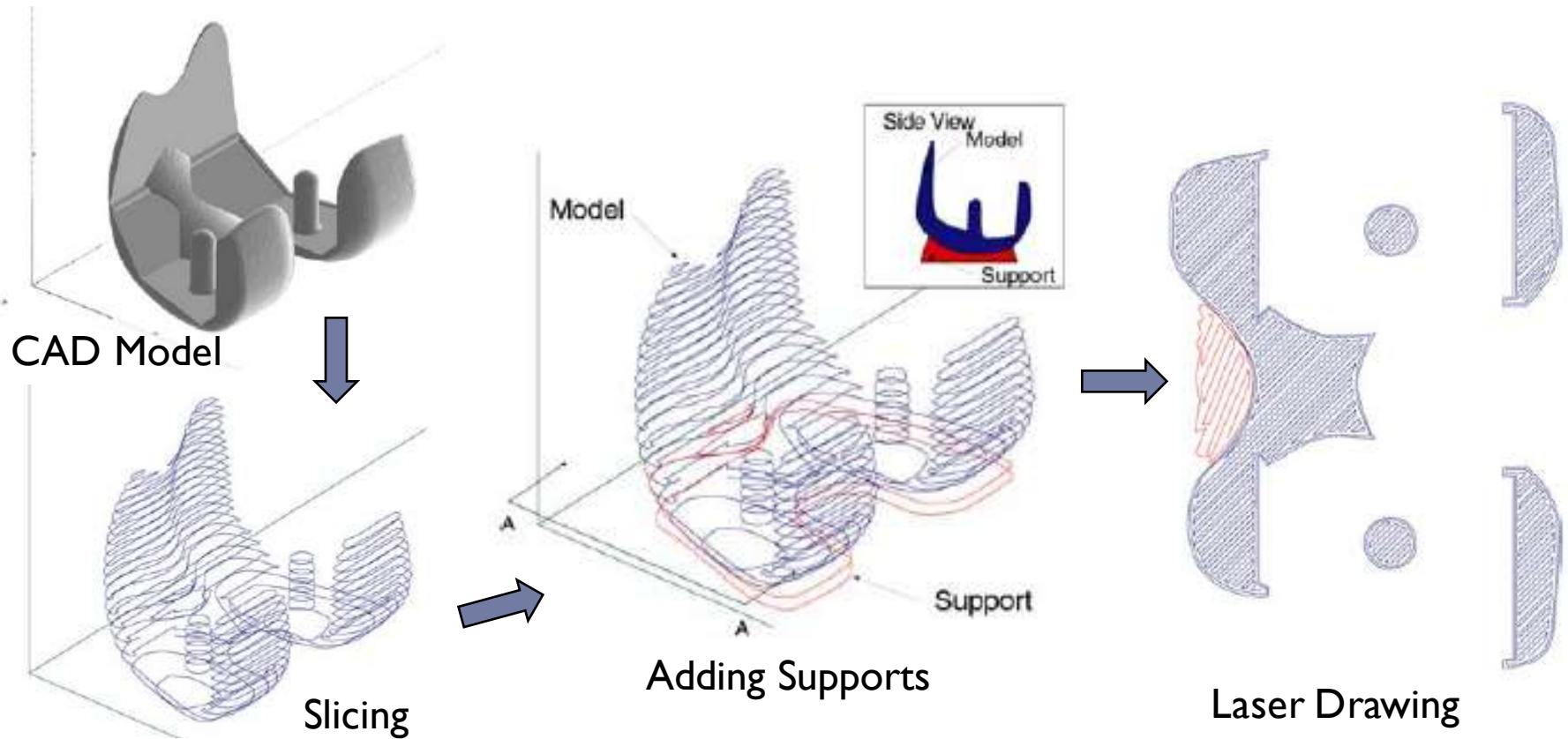

Numerical Robustness

- ▶ Computation in IEEE arithmetic
 - ▶ Limited precision of floating-point arithmetic
- ▶ Geometry becomes inexact after intersection
- ▶ Geometric predicates
 - ▶ Correct?
 - ▶ Self-intersected models?

Orientation

Does c lie on, to the left of,
or to the right of \vec{ab} ?

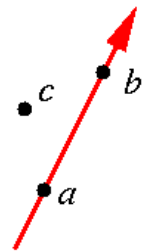

$$\begin{vmatrix} a_x & a_y & 1 \\ b_x & b_y & 1 \\ c_x & c_y & 1 \end{vmatrix} = \begin{vmatrix} a_x - c_x & a_y - c_y \\ b_x - c_x & b_y - c_y \end{vmatrix}$$

Problem of Inexact B-rep

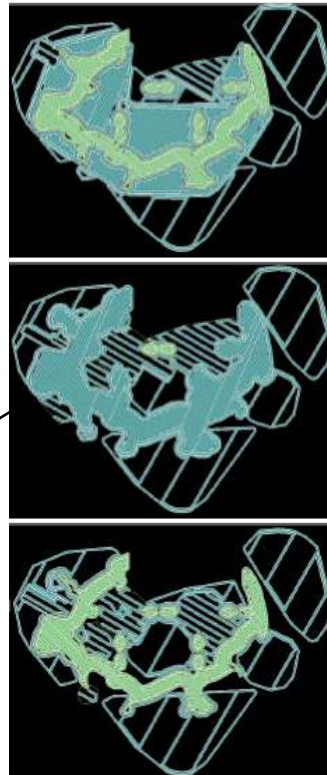
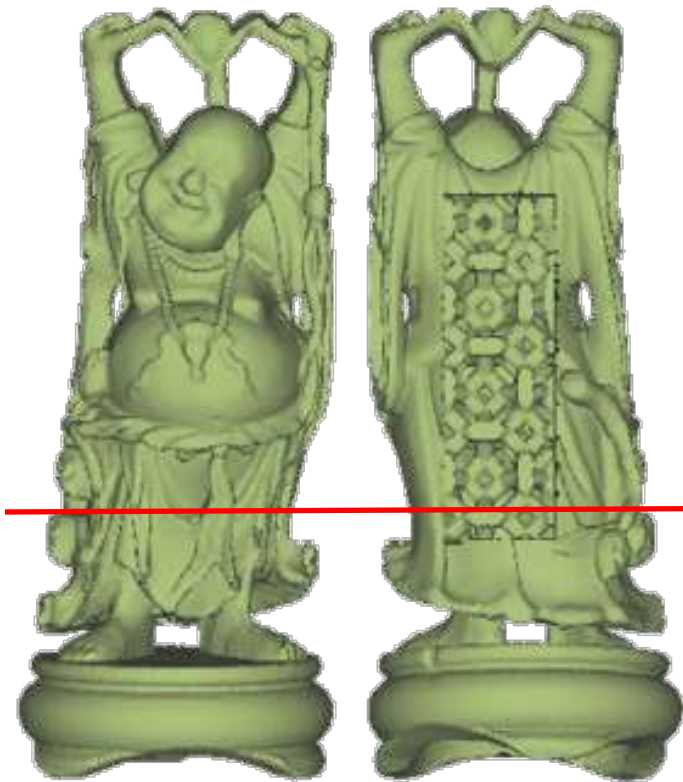

Can it be easily repaired?

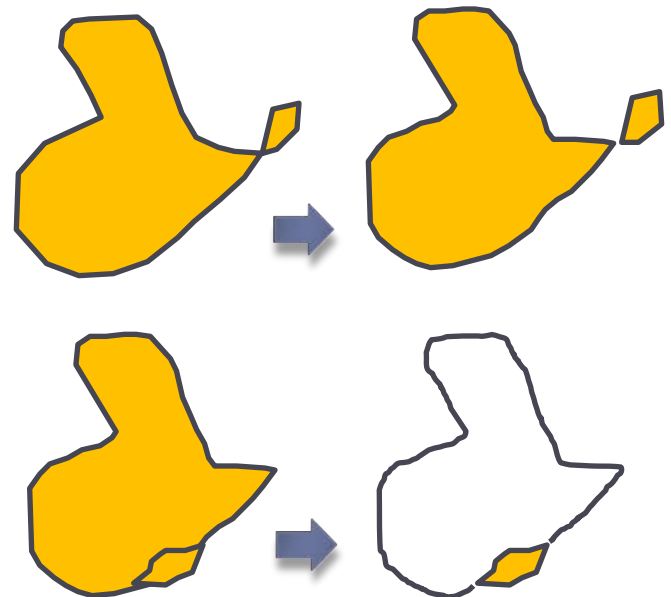

Problem of Inexact B-rep (Cont.)

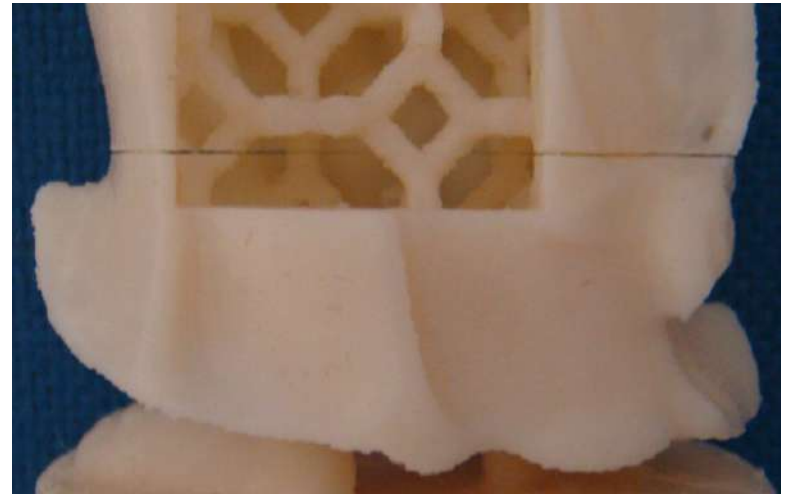

Robust Computation in Image Space

▶ Voxel representation

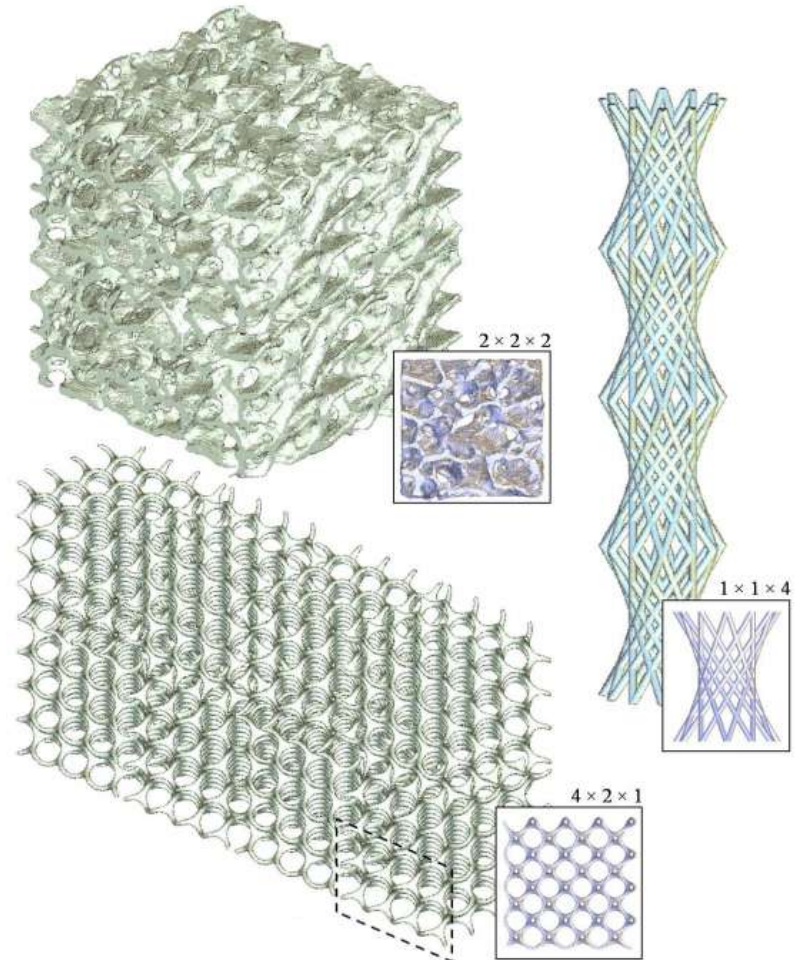
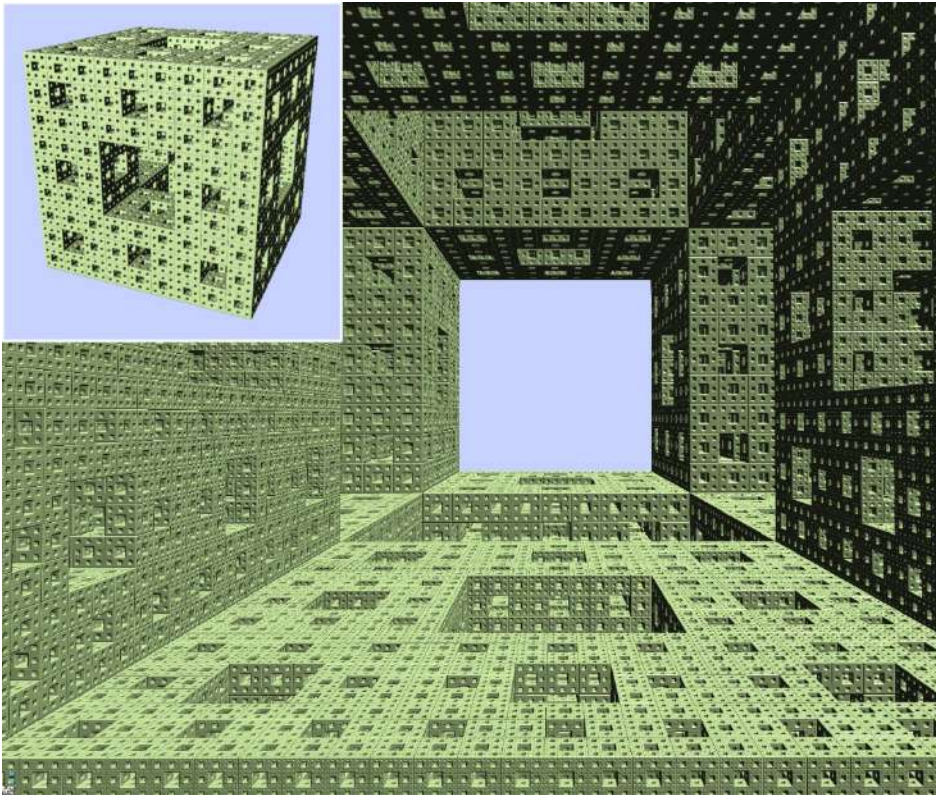

Problem: **Memory Cost** is extremely high

Supporting Structure?

Difference? Why and how?

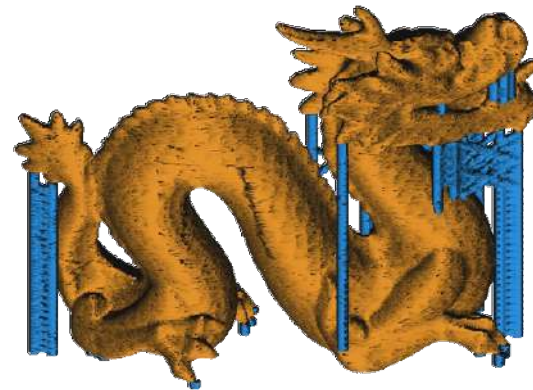
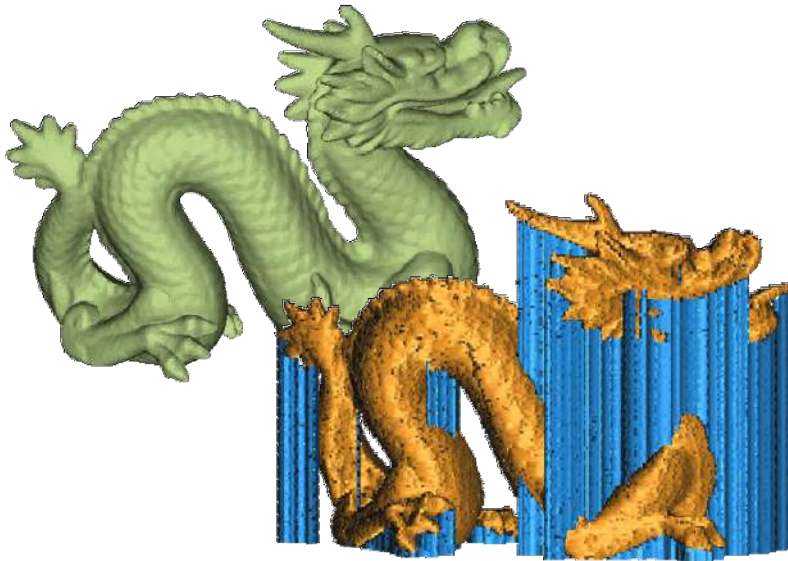

Multi-Materials:
Resolvable
materials for
supporting
structure



Single Material:
Using structures
to support

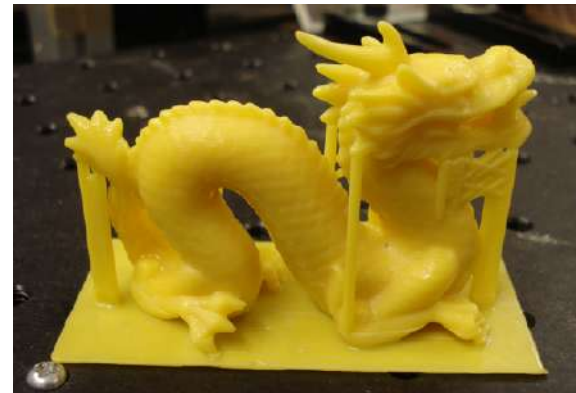

Support Structure Generation



Direct slicing and support generation resultant contour

Fabricated part with support

Fabricated part after removing support

GPU-based Implementation



2.5D vs 3D Printing

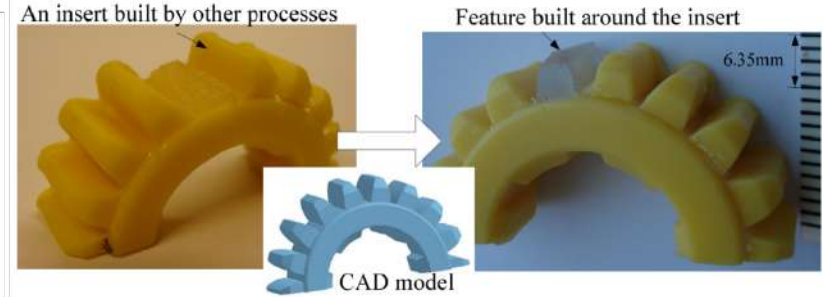
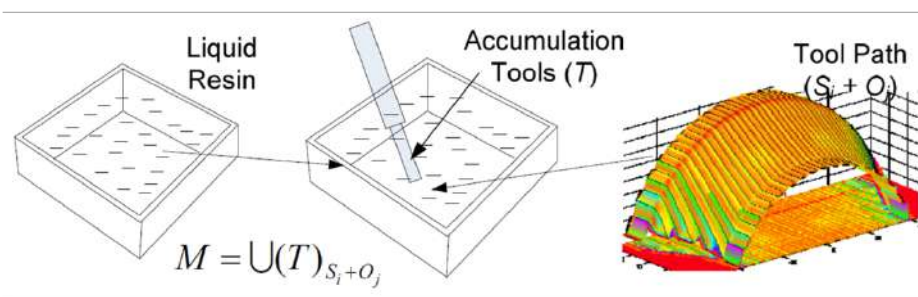

CNC accumulation for build-insert-around

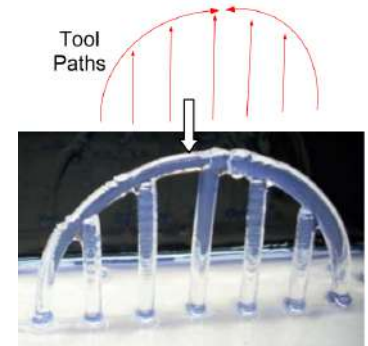
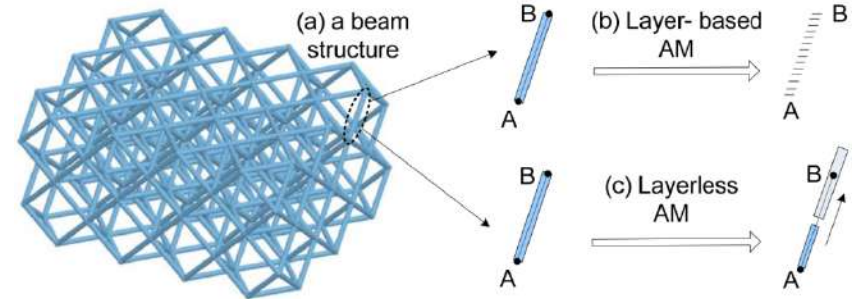
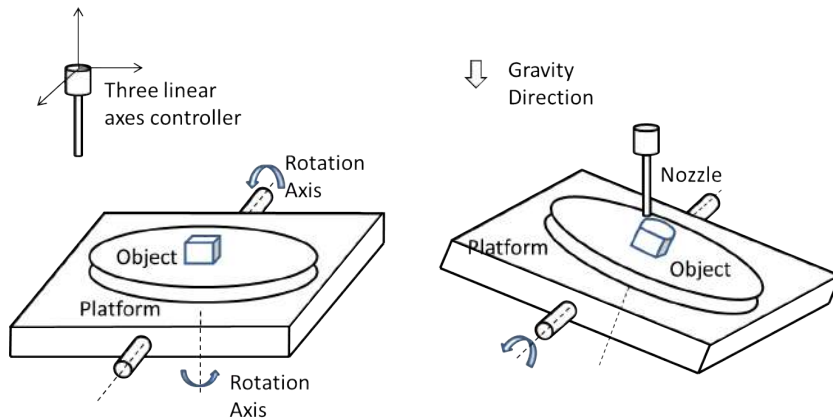

Develop a new **non-layered AM**

- Fused Deposition Modeling (FDM)
- Multi-axis motion introducing more flexibility

Robot-Assisted Additive Manufacturing

- ▶ Using robot arms as device for motion control in AM
- ▶ Collaborative operations on two arms – **More DoFs** to fabricate curved regions / layers
- ▶ Challenges:
 - ▶ Model **decomposition**
 - ▶ **Collision-free** tool path generation
 - ▶ Configurations in **joint-angle** space



vs

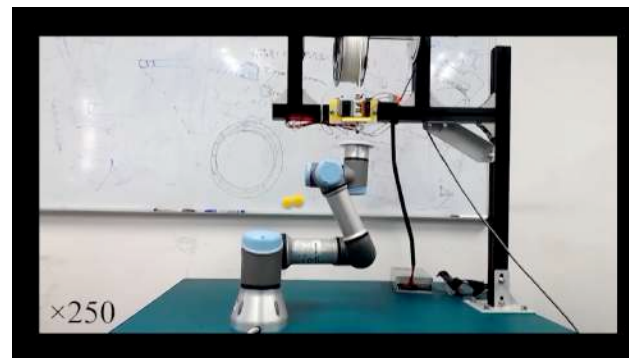

<https://youtu.be/mrR7IKpHo9k>

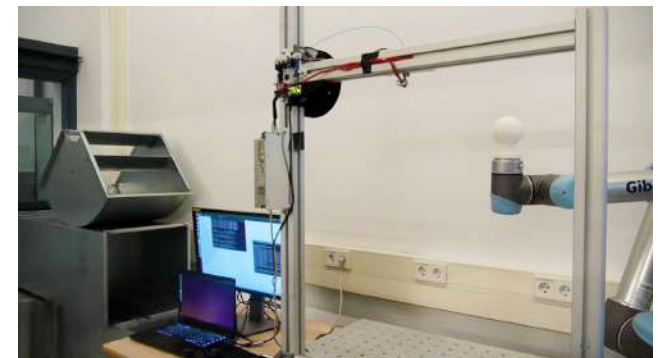

<https://youtu.be/5B37oz4cw9s>

From 3D to 4D Printing

- ▶ 3D Printed Self-Assembly Structures
- ▶ How to predict the shape of fabricated model?
- ▶ Pattern Design / Process Optimization / New Triggers



<https://youtu.be/vQB49vNFuI4>

Summary Remarks

- ▶ **Conventional** Manufacturing vs. **Additive** Manufacturing
- ▶ Reduce the **challenges** for designers
- ▶ Slicing and support generation
- ▶ Numerical **robustness**
- ▶ **Multi-axis** 3D printing
- ▶ **Robot**-assisted 3D printing
- ▶ 3D printed self-assembly structures (**4D printing**)

Thanks for Your Questions

Charlie C. L. Wang

Professor and Chair of Advanced Manufacturing
Department of Design Engineering
Delft University of Technology

Landbergstraat 15
2628 CE Delft
The Netherlands

Email: c.c.wang@tudelft.nl

URL: <http://www.io.tudelft.nl/en/organisation/personal-profiles/professors/wang-ccl/>

